



SPX Corporation
 655 Eisenhower Drive
 Owatonna, MN 55060-0995 USA
 Phone: (507) 455-7000
 Tech. Serv.: (800) 533-6127
 Fax: (800) 955-8329
 Order Entry: (800) 533-6127
 Fax: (800) 283-8665
 International Sales: (507) 455-7223
 Fax: (507) 455-7063

Form No. 102753

Parts List &
 Operating Instructions
 for:

5110

Air / Hydraulic Floor Service Jack

Max. Capacity: 10 Tons

Application: Designed to lift a wide range of motor vehicles.

This service jack is equipped with a manual foot and handle pump, along with an air-over hydraulic pump.

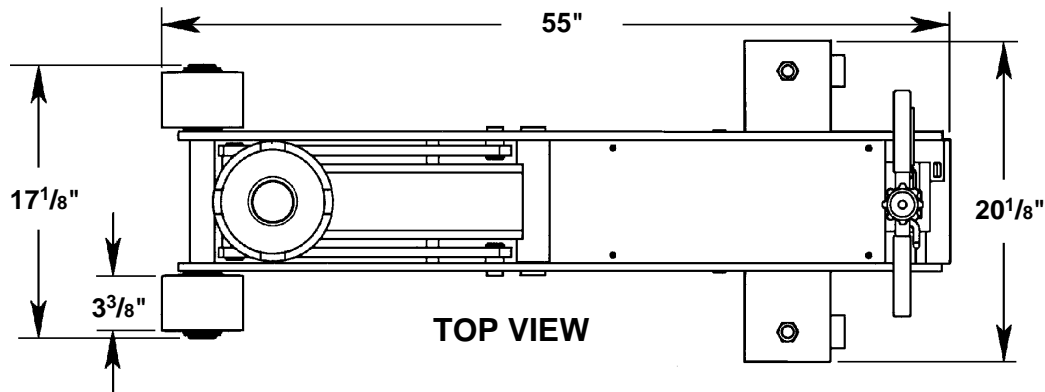

Rated Capacity: 20,000 lbs.
Air Supply: 90–175 psi
Weight: 410 lbs.

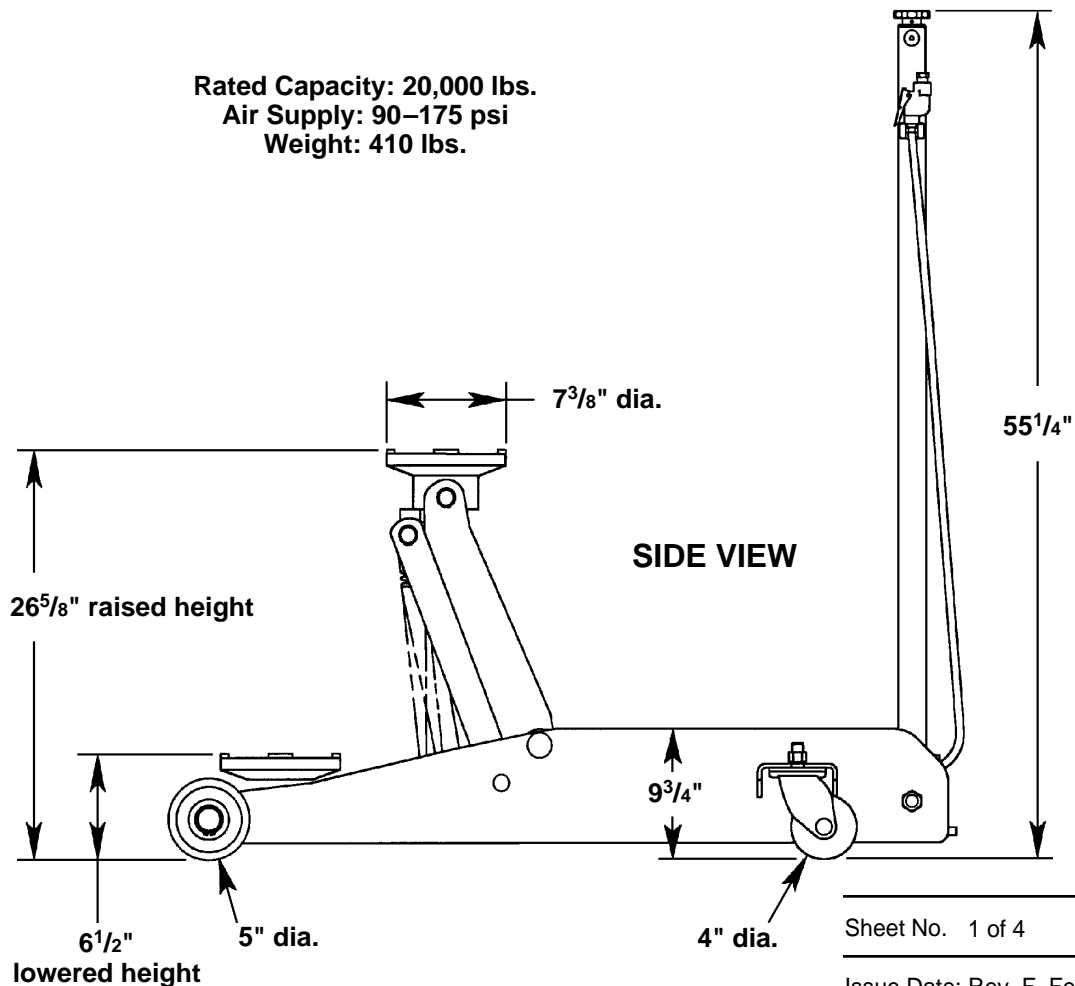

Sheet No. 1 of 4

Issue Date: Rev. F, February 1, 2007

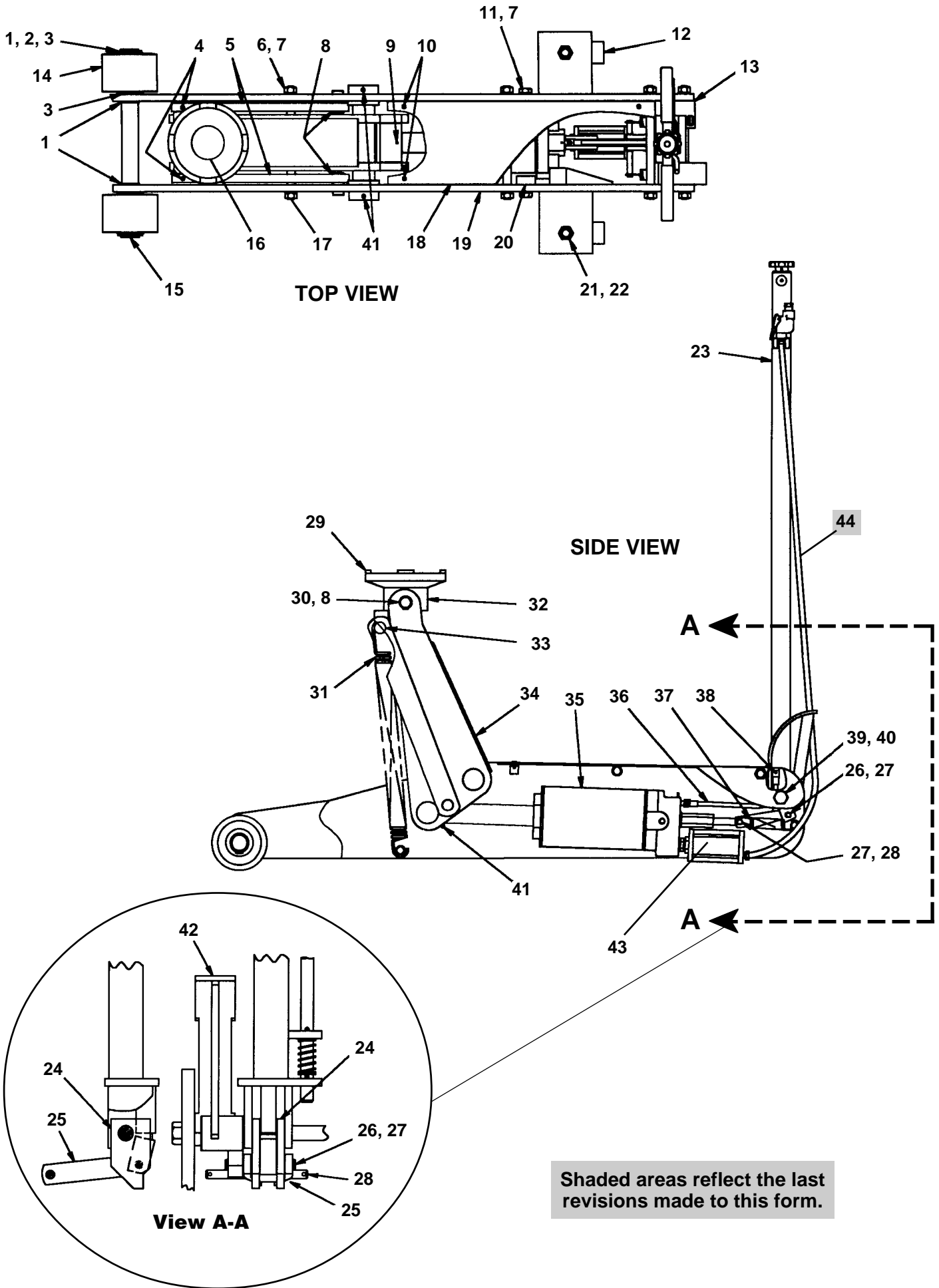

Item No.	Part No.	No. Req'd	Description
1	5110-01	4	External Retaining Ring (1 ¹ / ₂ " dia.)
2	5110-02	2	Flat Washer (1 ¹ / ₂ x 14 Ga.)
3	5110-03	4	Flanged Bearing (1.5 x 1.625 x 1.5)
4	5110-04	2	Roll Pin (⁵ / ₁₆ " dia.; 2" lg.)
5	5110-05	2	Leveling Link
6	5110-06	8	Hex Nut (⁵ / ₈ -11 UNC)
7	5110-07	10	Lockwasher (⁵ / ₈ " dia.)
8	5110-08	4	External Retaining Ring (1" dia.)
9	5110-09	1	Roll Pin (³ / ₁₆ " dia. x 2" lg.)
10	5110-10	4	Pan Hd. Screw (10-32 UNC x ¹ / ₂ " lg.)
11	5110-11	2	Cap Screw (⁵ / ₈ -11 UNC x 1 ¹ / ₂ " lg.)
12	5110-12	2	Swivel Caster (4" dia.; steel wheel)
13	5110-13	1	Frame Weldment (RH)
14	5110-14	2	Wheel and Grease Fitting Sub-assembly
15	5110-15	1	Front Axle
16	5110-16	1	Lift Pad Retainer
17	5110-17	4	Threaded Shaft (³ / ₄ " dia.)
18	5110-18	1	Top Cover
19	5110-19	1	Frame Rail Weldment (LH)
20	5110-20	2	Special Nut
21	5110-21	2	Hex Nut (³ / ₄ -10 UNC)
22	5110-22	2	Split Lockwasher (³ / ₄ " external tooth)
23	5110-23	1	Handle Sub-assembly
24	5110-24	1	Pump Pivot Link Weldment
25	5110-25	2	Pump Link
26	5110-26	1	Rear Pin Pump Link
27	5110-27	4	Heavy Duty External Retaining Ring (⁷ / ₁₆ " dia.)
28	5110-28	1	Front Pin Pump Link
29	5110-29	1	Lift Pad
30	5110-30	1	Lift Pad Pivot Shaft
31	5110-31	1	Spring (1 ¹⁵ / ₃₂ " dia. x 12.5" lg.)
32	5110-32	1	Lift Pad Bracket Weldment
33	5110-33	1	Front Pin Leveling Link
34	5110-34	1	Lift Arm Weldment
35	5110-35	1	Power Unit
36	5110-36	1	Flex Shaft
37	5110-37	2	Spring (¹⁵ / ₁₆ " O.D.)
38	5110-38	1	Roll Pin (³ / ₁₆ " dia. x ³ / ₄ " lg.)
39	5110-39	1	Cap Screw (³ / ₄ -10 UNC x 9.5" lg.; grade 8)
40	5110-40	1	Hex Nut (³ / ₄ -10 UNC)
41	5110-41	2	Grease Fitting (³ / ₁₆ " drive)
42	5110-42	1	Foot Pump Pivot Weldment
43	525394	1	Air Motor Assembly
44	531439	1	Air Hose with Fittings
	223119	1	Optional — Seal Repair Kit to Service Pump/Ram
	518087	1	Optional — Seal Repair Kit (Use on jacks with a serial no. of 78-003914 and higher. Use also on power units purchased in November, 2002, and later.)

Shaded areas reflect the last revisions made to this form.

Sheet No. 2 of 4

Issue Date: Rev. F, February 1, 2007

518087 Seal Repair Kit

Hydraulic Unit

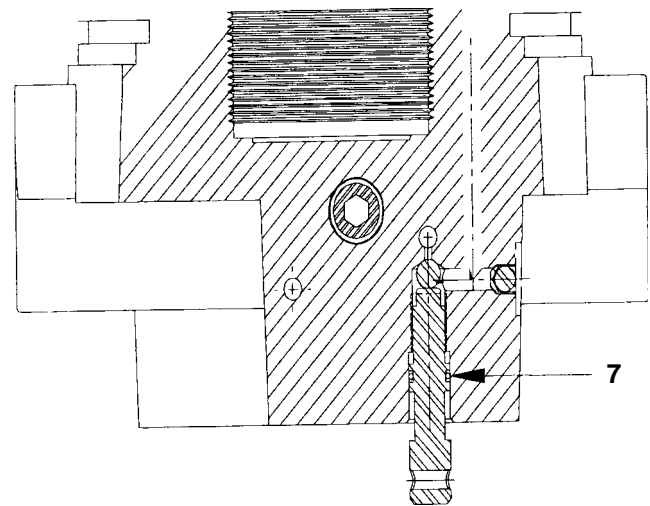
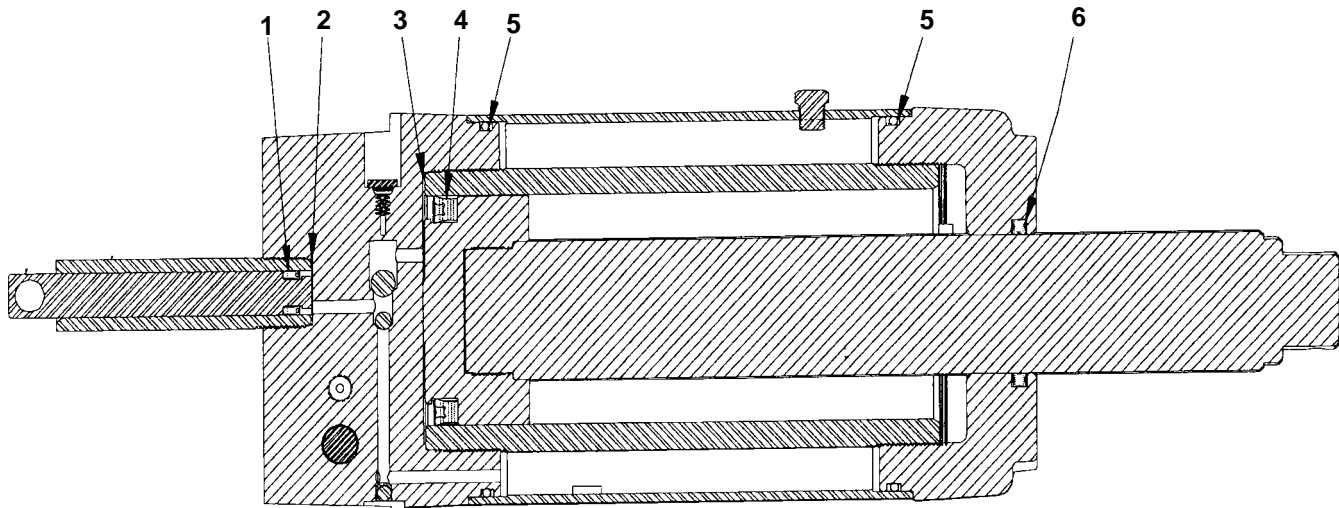

Item No.	Description
1	Seal, $\frac{5}{8}$ " O.D. x $\frac{3}{8}$ " I.D. x $\frac{1}{4}$ " Type B
2	Back-up Ring, $\frac{15}{16}$ " x $\frac{3}{4}$ " x .040" Thick
3	Back-up Ring, $\frac{3}{4}$ " x $\frac{3}{8}$ " x .055" Thick
4	Seal, 2 $\frac{1}{2}$ " I.D. x 3 $\frac{1}{4}$ " O.D. x $\frac{3}{8}$ "
5	O-ring, 5" I.D. x 5 $\frac{1}{4}$ " O.D. x $\frac{1}{8}$ " CS
6	Quad Seal, 2" I.D. x 2 $\frac{3}{8}$ " O.D. x $\frac{3}{16}$ " CS
7	O-ring, $\frac{7}{16}$ " I.D. x $\frac{5}{16}$ " O.D. x $\frac{1}{16}$ " CS

525394 Air Motor Assembly

Item No.	Description
1	Seal, Shuttle Valve
2	O-ring, 2 $\frac{1}{4}$ " x $\frac{1}{16}$ " x 2 $\frac{1}{8}$ "
3	Quad Ring, 3" O.D. x 2 $\frac{5}{8}$ " x $\frac{3}{16}$ "
4	Seal, 1 $\frac{1}{4}$ " O.D. x 1" I.D. x $\frac{1}{8}$ " W
5	Seal, .277" I.D. x .528" O.D. x .188" Type B
6	Spring (This spring can be ordered separately under No. 525198.)

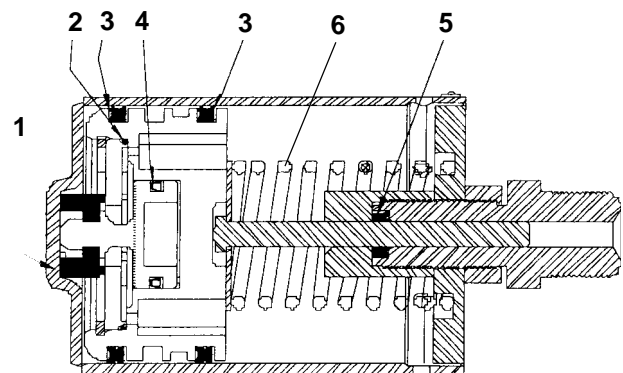

Safety Precautions



Caution: To prevent personal injury and damage to equipment,



- Study, understand, and follow all instructions, including ASME PALD Part 10 for service jacks.
- If the operator cannot read these instructions, operating instructions and safety precautions must be read and discussed in the operator's native language.
- Before using the service jack to lift a vehicle, refer to the vehicle service manual to determine recommended lifting surfaces on the vehicle chassis.



- Wear eye protection that meets ANSI Z87.1 and OSHA standards.
- Inspect the jack before each use; do not use the jack if it's damaged, altered, or in poor condition. Take corrective action if any of the following conditions are found: cracked or damaged housing; excessive wear, bending, or other damage; leaking hydraulic fluid; scored or damaged piston rod; loose hardware; modified or altered equipment.



- A load must never exceed the rated lifting capacity of the jack.
 - Only use the jack on a hard, level surface.
 - Use the jack for lifting purposes only. Stay clear of a lifted load. Place support stands under the axles before working on the vehicle.
- Center the load on the jack saddle. Off-center loads can damage seals and cause jack failure. Lift only dead weight.
 - Do not use blocks or other extenders between the saddle and the load being lifted.
 - Do not modify the jack or use adapters unless approved or supplied by OTC. Do not adjust the safety valve.
 - Lower the jack slowly and carefully while watching the position of the jack saddle.
 - Use only approved hydraulic fluid (Mobil DTE #11 or equivalent). The use of alcohol, hydraulic brake fluid, or automatic transmission fluid (ATF) could damage seals and result in jack failure.

This guide cannot cover every situation, so always do the job with safety first.

Operating Instructions

1. Connect the shop air supply to the jack. (90–175 psi of clean, dry air is required for the capacity of this jack.)
2. Position the jack under the vehicle using the manufacturer's recommended lifting points on the chassis.
3. Close the release valve by turning the knob clockwise (CW) as far as it will go.
4. Press the air valve lever to raise the jack saddle until it touches the vehicle.
5. Check the placement of the jack; the load must be centered on the jack saddle. **IMPORTANT: Avoid wheel obstructions such as gravel, tools, or uneven expansion joints. The jack must be free to roll forward 11 inches during lifting, and backward 11 inches during lowering. The load could become unstable, or even fall off the saddle, if the rolling movement of the jack is impaired.**
6. Finish lifting the vehicle.
7. Place approved support stands under the vehicle at points that will provide stable support. Before making repairs on the vehicle, lower it onto the support stands by SLOWLY and carefully turning the release knob counterclockwise (CCW).

Adding Hydraulic Fluid

1. Remove the jack from service, and place it on a level surface.
2. Lower the lift arm completely.
3. Disassemble the top cover by removing the four pan head screws.
4. Clean around the surface of the oil fill plug; this will help prevent contamination of the hydraulic oil system.
5. Remove the oil fill plug, and check the hydraulic oil level. The fluid should be visible and just covering the hydraulic cylinder. If the fluid level is low, add a high-grade hydraulic fluid equivalent to Mobil DTE #11 until the oil level just covers the cylinder.
6. Install the oil fill plug. Clean up any spilled oil, and secure the top cover back onto the frame.
7. Test the jack for normal operation. If the lift pad doesn't rise to the correct height, repeat Steps 2–6, adding two more ounces of oil. If this doesn't solve the problem, call the OTC Technical Services Dept.

Preventive Maintenance

IMPORTANT: The greatest single cause of failure in hydraulic units is dirt. Keep the service jack clean and well lubricated to prevent foreign matter from entering the system. If the jack has been exposed to rain, snow, sand, or grit, it must be cleaned before it is used.

1. Store the jack in a well-protected area where it will not be exposed to corrosive vapors, abrasive dust, or any other harmful elements.
2. Lubricate rotating and sliding parts at least once per month.
3. Lubricate the air inlet on the jack using 1/2 oz. clean lubricating oil; lack of oil may cause pump malfunction.
4. Grease the jack once a month using a good bearing grease. (There are grease fittings located on the pivot tube of the lift arm, the block on the rod end of the cylinder, and on all four wheels of the jack.)
5. Keep warning labels and instructional decals clean and readable. Use a mild soap solution to wash the external surfaces of the jack.
6. Replace the oil in the reservoir at least once per year.
7. Inspect the jack before each use. Take corrective action if any of the following problems are found:
 - a. Cracked or damaged housing
 - b. Excessive wear, bending, or other damage
 - c. Leaking hydraulic fluid
 - d. Scored or damaged piston rod
 - e. Loose hardware
 - f. Modified or altered equipment

Troubleshooting Guide

Repair procedures must be performed in a dirt-free environment by qualified personnel who are familiar with this equipment. **CAUTION: All inspection, maintenance, and repair procedures must be performed when the jack is free of a load (not in use).**

Trouble	Cause	Solution
Failure to lift a load	<ol style="list-style-type: none"> 1. Low oil level 2. Air line leaks. 3. Inadequate air pressure. 4. Release knob open. 5. Jack is overloaded. 	<ol style="list-style-type: none"> 1. Refer to the section <i>Adding Hydraulic Fluid</i>. 2. Locate leak, tighten connections, and/or replace hose. 3. Set air pressure at 90–175 psi. 4. Close release knob. 5. Use equipment that has the correct capacity for the job.
Failure to hold a load	<ol style="list-style-type: none"> 1. Release knob not closed. 	<ol style="list-style-type: none"> 1. Turn release knob clockwise to tighten securely.
Air motor won't run, or runs erratically	<ol style="list-style-type: none"> 1. Leak in air line. 2. Air piston is sticking. 3. Inadequate air pressure. 	<ol style="list-style-type: none"> 1. Locate leak, tighten connections, and/or replace hose. 2. Add small amount of oil to jack's air inlet to lube air motor. 3. Set air pressure at 90–175 psi.
Reservoir leaks	<ol style="list-style-type: none"> 1. Loose oil fill plug. 2. Reservoir is overfilled. 	<ol style="list-style-type: none"> 1. Tighten oil fill plug. 2. Drain some oil from reservoir.

